

## PIPE TO MANHOLE & TANK CONNECTOR



Cast-A-Dapter is a rubber adapter that provides flexible, watertight sealing of single or multiple pipes and conduits into on-site treatment tanks, and pump stations. Used with our Cast-A-Seal® 402 cast-in flexible connector, Cast-A-Dapter is available in a wide variety of pipe diameter combinations to meet the needs of any tank design or specification.

### How It Works

- Pipes are installed through Cast-A-Dapter and alignment plug.
- The plug is taped in place and the entire assembly is inserted into the Cast-A-Seal 402.
- Stainless steel clamps are then tightened down to create watertight seal.

### Where To Use

- Manholes
- Wet wells
- Square pump and lift stations
- Stormwater structures
- On-site treatment structures
- Junction chambers
- Grease interceptors

- Can accommodate a variety of pipe OD's used with the Cast-A-Seal 402.
- Multiple pipe in one connector reduces the number of openings in tank walls.
- One hole can be used for electrical conduit



**CAST-A-DAPTER is designed exclusively for 3/4" to 2 1/2" Schedule 40/80/120 PVC pipe and conduit. Consult Cast-A-Dapter selection guide for applications.**

Press-Seal believes all information is accurate as of its publication date. Information, specifications, and prices are all subject to change without notice. Press-Seal is not responsible for any inadvertent errors. Copyright 2022.

Phone: 800-348-7325  
Fax: (260) 436-1908

**PRESS-SEAL CORPORATION**  
*Protecting Our Planet's Clean Water Supply*  
ISO 9001: Registered • Version 02.16.22.11.17

Email: sales @press-seal.com  
Web: www.press-seal.com



## SUBMITTAL SPECIFICATIONS

A flexible pipe-to-structure connector shall be employed in the connection of the sanitary sewer pipe to precast tanks or structures. The connector shall be Cast-A-Seal® 402 and CAST-A-DAPTER as manufactured by Press-Seal Corporation, Fort Wayne, Indiana, or approved equal. The connector/adapter shall be the sole element relied on to assure a flexible, watertight seal of the pipe to the precast structure. The connector/adapter shall consist of a rubber gasket, a rubber adapter, an alignment plug (on multi-pipe models), and an external take-up clamp.

The rubber elements shall be constructed solely of synthetic or natural rubber, and shall meet or exceed the physical property requirements of ASTM C 923.

The external take-up clamp shall be constructed of Series 300 non-magnetic stainless steel and shall utilize no welds in its construction.

The clamp shall be installed by torquing the adjusting screw using a torque-setting wrench available from the connector manufacturer.

Selection of the proper size connector and adapter for the structure and pipe requirement, and installation thereof, shall be in strict conformance with the recommendations of the connector manufacturer. Any dead end pipe stubs installed in connectors shall be restrained from movement per ASTM C 923.

The finished connection shall provide sealing to 13 psi (minimum) and shall accommodate deflection of the pipe to 7 degrees (minimum) without loss of seal.

Vacuum testing shall be conducted in strict conformance with ASTM C 1244 prior to backfill. Other testing shall be conducted in strict conformance with the requirements of the connector manufacturer.

---

CAST-A-DAPTER (used with Cast-A-Seal 402) meets and/or exceeds all requirements of ASTM C 923, including physical properties of materials and performance testing, including:

- 13 PSI minimum in straight alignment
- 10 PSI at minimum 7° angle
- 10 PSI minimum under ultimate shear load

CAST-A-DAPTER meets the requirements of the following Standards, Specifications, Codes, and Test Methods:

- ASTM C 923 Standard Specification for Resilient Connectors Between Reinforced Concrete Manhole Structures, Pipes, and Laterals
- ASTM C 1644 Standard Specification for Resilient Connectors Between Reinforced Concrete On-Site Wastewater Tanks and Pipes
- ASTM C 1478 Standard Specification for Storm Drain Resilient Connectors Between Reinforced Concrete Storm Sewer Structures, Pipes, and Laterals
- ASTM C 1244 Standard Test Method for Concrete Sewer Manholes by the Negative Air Pressure (Vacuum) Test
- IAPMO/ANSI Z1000 Standard for Prefabricated Septic Tanks
- IAPMO/ANSI Z1001 Standard for Prefabricated Gravity Grease Interceptors
- NPCA Best Practices Manual for Precast Concrete On-Site Wastewater Tanks
- NOWRA Model Code Framework
- Florida Department of Health Product Approval



Press-Seal believes all information is accurate as of its publication date. Information, specifications, and prices are all subject to change without notice. Press-Seal is not responsible for any inadvertent errors. Copyright 2022.

Phone: 800-348-7325  
Fax: (260) 436-1908

**PRESS-SEAL CORPORATION**  
*Protecting Our Planet's Clean Water Supply*  
ISO 9001: Registered • Version 02.16.22.11.17

Email: sales @press-seal.com  
Web: www.press-seal.com

## SELECTION GUIDE

All for use with Cast-A-Seal 402 Connector

CAD Part Number	First PVC Pipe (Schedule 40/80/120)	First Hole ID	Second PVC Pipe (Schedule 40/80/120)	Second Hole ID	Alignment Plug
452.075.075.CA	3/4" PVC	1.050	3/4" PVC	1.050	Yes
452.100.075.CA	1" PVC	1.315	3/4" PVC	1.050	Yes
452.100.100.CA	1" PVC	1.315	1" PVC	1.315	Yes
452.125.075.CA	1-1/4" PVC	1.660	3/4" PVC	1.050	Yes
452.125.100.CA	1-1/4" PVC	1.660	1" PVC	1.315	Yes
452.125.125.CA	1-1/4" PVC	1.660	1-1/4" PVC	1.660	Yes
452.150.CA	1-1/2" PVC	1.900	None	----	----
452.150.075.CA	1-1/2" PVC	1.900	3/4" PVC	1.050	Yes
452.150.100.CA	1-1/2" PVC	1.900	1" PVC	1.315	Yes
452.150.125.CA	1-1/2" PVC	1.900	1-1/4" PVC	1.660	Yes
452.150.150.CA	1-1/2" PVC	1.900	1-1/2" PVC	1.900	Yes
452.200.CA	2" PVC	2.375	None	----	----
452.200.075.CA	2" PVC	2.375	3/4" PVC	1.050	Yes
452.200.100.CA	2" PVC	2.375	1" PVC	1.315	Yes
452.200.125.CA	2" PVC	2.375	1-1/4" PVC	1.660	Yes
452.200.150.CA	2" PVC	2.375	1-1/2" PVC	1.900	Yes
452.250.CA	2-1/2" PVC	2.875	None	----	---
452.250.075.CA	2-1/2" PVC	2.875	3/4" PVC	1.050	Yes
452.250.100.CA	2-1/2" PVC	2.875	1" PVC	1.315	Yes
452.0350	3-1/2" PVC	3.625	None	----	---

Press-Seal believes all information is accurate as of its publication date. Information, specifications, and prices are all subject to change without notice. Press-Seal is not responsible for any inadvertent errors. Copyright 2022.



## INSTALLATION INSTRUCTIONS

1. Install pipes through the Cast-A-Dapter and alignment plug.
2. Tape plug in place.
3. Insert the assembly through the Cast-A-Seal 402 and into the tank.
4. Align the Cast-A-Dapter with the outside edge of the Cast-A-Seal 402 and tighten the clamp to 60 in/lbs.
5. Complete all plumbing connections inside and outside the tank.
6. Backfill carefully to prevent the shear loading or spreading of the pipes.

## ITEMS NEEDED

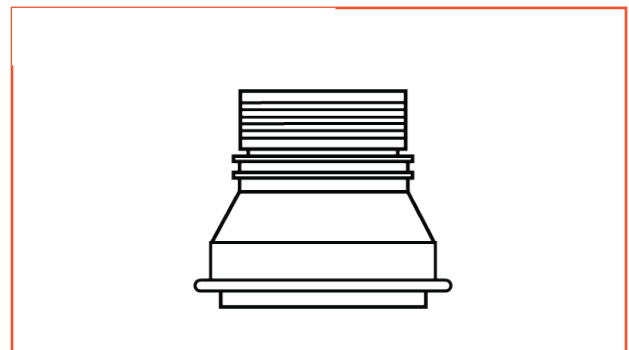
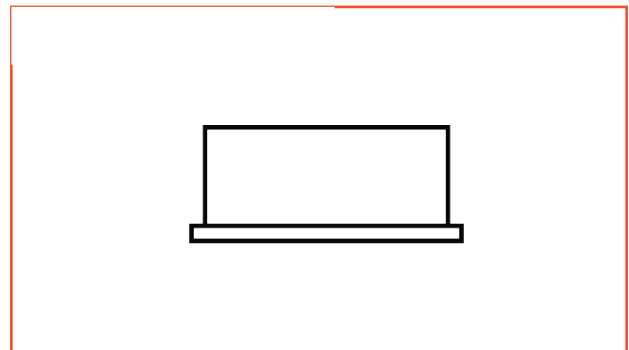
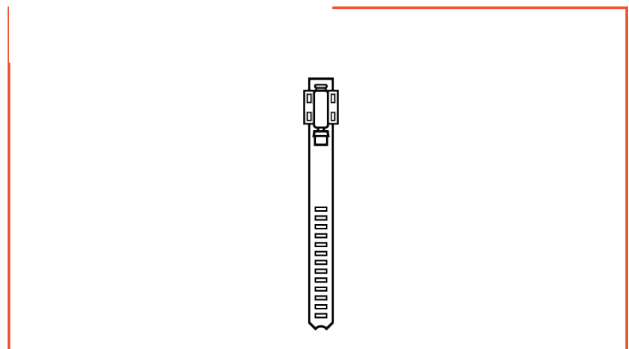
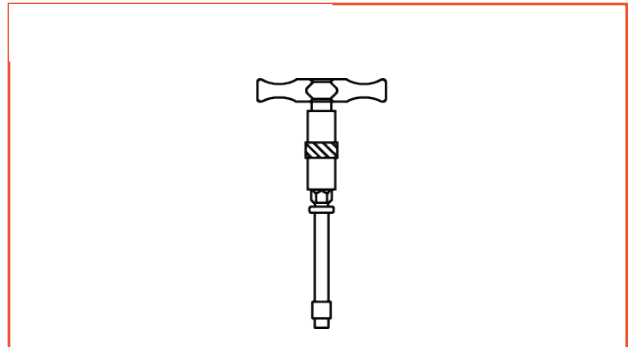

Phone: 800-348-7325  
 Fax: (260) 436-1908

**PRESS-SEAL CORPORATION**  
 Protecting Our Planet's Clean Water Supply  
ISO 9001: Registered • Version 02.16.22.11.17

Email: sales @press-seal.com  
 Web: www.press-seal.com

Press-Seal believes all information is accurate as of its publication date. Information, specifications, and prices are all subject to change without notice. Press-Seal is not responsible for any inadvertent errors. Copyright 2022.